



2.5-V/3.3-V OSCILLATOR GAIN STAGE/BUFFERS

FEATURES

- Low-Voltage PECL Input and Low-Voltage PECL or LVDS Outputs
- Clock Rates to 2 GHz
 - 140-ps Output Transition Times
 - 0.11 ps Typical Intrinsic Phase Jitter
 - Less than 630 ps Propagation Delay Times
- 2.5-V or 3.3-V Supply Operation

- 2-mm × 2-mm Small-Outline No-Lead Package

APPLICATIONS

- PECL-to-LVDS Translation
- Clock Signal Amplification

DESCRIPTION

These four devices are high-frequency oscillator gain stages supporting both LVPECL or LVDS on the high gain outputs in 3.3-V or 2.5-V systems. Additionally, provides the option of both single-ended input (PECL levels on the SN65LVx16) and fully differential inputs on the SN65LVx17.

The SN65LVx16 provides the user a Gain Control (GC) for controlling the \bar{Q} output from 300 mV to 860 mV either by leaving it open (NC), grounded, or tied to V_{CC} . (When left open, the \bar{Q} output defaults to 575 mV.) The \bar{Q} on the SN65LVx17 defaults to 575 mV as well.

Both devices provide a voltage reference (V_{BB}) of typically 1.35 V below V_{CC} for use in receiving single-ended PECL input signals. When not used, V_{BB} should be unconnected or open.

All devices are characterized for operation from -40°C to 85°C .

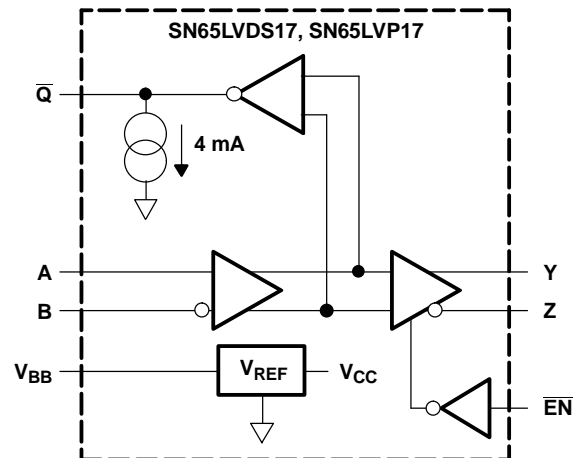
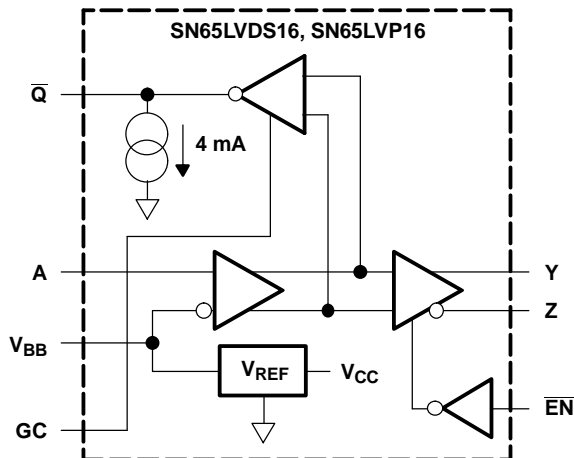

Please be aware that an important notice concerning availability, standard warranty, and use in critical applications of Texas Instruments semiconductor products and disclaimers thereto appears at the end of this data sheet.



These devices have limited built-in ESD protection. The leads should be shorted together or the device placed in conductive foam during storage or handling to prevent electrostatic damage to the MOS gates.

AVAILABLE OPTIONS⁽¹⁾

INPUT	OUTPUT	GAIN CONTROL	BASE PART NUMBER	PART MARKING
Single-ended	LVDS	Yes	SN65LVDS16	EL
Single-ended	LVPECL	Yes	SN65LVP16	EK
Differential	LVDS	No	SN65LVDS17	EN
Differential	LVPECL	No	SN65LVP17	EM

(1) For the most current package and ordering information, see the Package Option Addendum at the end of this document, or see the TI website at www.ti.com.

ABSOLUTE MAXIMUM RATINGS

over operating free-air temperature range (unless otherwise noted) ⁽¹⁾

	UNIT
V _{CC} Supply voltage ⁽²⁾	-0.5 V to 4 V
V _I Input voltage	-0.5 V to V _{CC} + 0.5 V
V _O Output voltage	-0.5 V to V _{CC} + 0.5 V
I _O V _{BB} output current	±0.5 mA
HBM electrostatic discharge ⁽³⁾	±3 kV
CDM electrostatic discharge ⁽⁴⁾	±1500 V
Continuous power dissipation	See Power Dissipation Ratings Table

(1) Stresses beyond those listed under "absolute maximum ratings" may cause permanent damage to the device. These are stress ratings only and functional operation of the device at these or any other conditions beyond those indicated under "recommended operating conditions" is not implied. Exposure to absolute-maximum-rated conditions for extended periods may affect device reliability.

(2) All voltage values, except differential voltages, are with respect to network ground see Figure 1).

(3) Tested in accordance with JEDEC Standard 22, Test Method A114-A-7

(4) Tested in accordance with JEDEC Standard 22, Test Method C101

DISSIPATION RATINGS

PACKAGE	CIRCUIT BOARD MODEL	T _A ≤ 25°C POWER RATING	DERATING FACTOR ABOVE T _A = 25°C ⁽¹⁾	T _A = 85°C POWER RATING
DRF	Low-K ⁽²⁾	403 mW	4.0 mW/°C	161 mW
	High-K ⁽³⁾	834 mW	8.3 mW/°C	333 mW

(1) This is the inverse of the junction-to-ambient thermal resistance when board-mounted and with no air flow.

(2) In accordance with the Low-K thermal metric definitions of EIA/JESD51-3.

(3) In accordance with the High-K thermal metric definitions of EIA/JESD51-7.

THERMAL CHARACTERISTICS

over operating free-air temperature range (unless otherwise noted)

PARAMETER	TEST CONDITIONS	VALUE	UNIT	
θ _{JB} Junction-to-board thermal resistance		93.3	°C/W	
θ _{JC} Junction-to-case thermal resistance		101.7		
P _D Device power dissipation	Typical	V _{CC} = 3.3 V, T _A = 25°C, 2 GHz, LVDS	132	
		V _{CC} = 3.3 V, T _A = 25°C, 2 GHz, LVPECL	83	
	Maximum	V _{CC} = 3.6 V, T _A = 85°C, 2 GHz, LVDS	173	mW
		V _{CC} = 3.6 V, T _A = 85°C, 2 GHz, LVPECL	108	

RECOMMENDED OPERATING CONDITIONS

			MIN	NOM	MAX	UNIT
V_{CC}	Supply voltage		2.375	2.5 or 3.3	3.6	V
V_{IC}	Common-mode input voltage ($V_{IA} + V_{IB}$)/2	SN65LVDS17 or SN65LVP17	1.2	$V_{CC} - (V_{ID}/2)$		V
$ V_{ID} $	Differential input voltage magnitude $ V_{IA} - V_{IB} $	SN65LVDS17 or SN65LVP17	0.08		1	V
V_{IH}	High-level input voltage to \overline{EN}	\overline{EN}	2		V_{CC}	V
		SN65LVDS16 or SN65LVP16	$V_{CC} - 1.17$		$V_{CC} - 0.44$	
V_{IL}	Low-level input voltage to \overline{EN}	\overline{EN}	0		0.8	V
		SN65LVDS16 or SN65LVP16	$V_{CC} - 2.25$		$V_{CC} - 1.52$	
I_O	Output current to V_{BB}		$-400^{(1)}$		400	μ A
R_L	Differential load resistance,		90		132	Ω
T_A	Operating free-air temperature		-40		85	$^{\circ}$ C

(1) The algebraic convention, where the least positive (more negative) value is designated minimum, is used in this data sheet.

ELECTRICAL CHARACTERISTICS

over recommended operating conditions (unless otherwise noted)

PARAMETER	TEST CONDITIONS	MIN	TYP ⁽¹⁾	MAX	UNIT	
I_{CC}	Supply current		40	48	mA	
	$R_L = 100 \Omega$, \overline{EN} at 0 V, Other inputs open					
	Outputs unloaded, \overline{EN} at 0 V, Other inputs open		25	30		
V_{BB}	Reference voltage ⁽²⁾	$I_{BB} = -400 \mu$ A	$V_{CC} - 1.44$	$V_{CC} - 1.35$	$V_{CC} - 1.25$	V
I_{IH}	High-level input current, \overline{EN}	$V_I = 2$ V	-20		20	μ A
I_{IAH} or I_{IBH}	High-level input current, A or B	$V_I = V_{CC}$	-20		20	
I_{IL}	Low-level input current, \overline{EN}	$V_I = 0.8$ V	-20		20	
I_{IAL} or I_{IBL}	Low-level input current, A or B	$V_I = GND$	-20		20	
SN65LVDS16/17 Y AND Z OUTPUT CHARACTERISTICS						
$ V_{OD} $	Differential output voltage magnitude, $ V_{OY} - V_{OZ} $	See Figure 1 and Figure 2	247	340	454	mV
$\Delta V_{OD} $	Change in differential output voltage magnitude between logic states				50	
$V_{OC(SS)}$	Steady-state common-mode output voltage (see Figure 3)			1.125		1.375
$\Delta V_{OC(SS)}$	Change in steady-state common-mode output voltage between logic states	See Figure 3	-50		50	mV
$V_{OC(PP)}$	Peak-to-peak common-mode output voltage			50		
I_{OYZ} or I_{OZZ}	High-impedance output current	\overline{EN} at V_{CC} , $V_O = 0$ V or V_{CC}	-1		1	μ A
I_{OYS} or I_{OZS}	Short-circuit output current	\overline{EN} at 0 V, V_{OY} or $V_{OZ} = 0$ V	-62		62	mA
$I_{OS(D)}$	Differential short-circuit output current, $ I_{OY} - I_{OZ} $	\overline{EN} at 0 V, $V_{OY} = V_{OZ}$	-12		12	

(1) Typical values are at room temperature and with a V_{CC} of 3.3 V.

(2) Single-ended input operation is limited to $V_{CC} \geq 3.0$ V.

ELECTRICAL CHARACTERISTICS (continued)

over recommended operating conditions (unless otherwise noted)

PARAMETER		TEST CONDITIONS	MIN	TYP ⁽¹⁾	MAX	UNIT
SN65LVP16/17 Y AND Z OUTPUT CHARACTERISTICS						
V_{OYH} or V_{OZH}	High-level output voltage	3.3 V; 50 Ω from Y and Z to $V_{CC}-2$ V	$V_{CC}-1.05$		$V_{CC}-0.82$	V
V_{OYL} or V_{OZL}	Low-level output voltage		$V_{CC}-1.83$		$V_{CC}-1.57$	
V_{OYL} or V_{OZL}	Low-level output voltage		$V_{CC}-1.88$		$V_{CC}-1.57$	
$ V_{OD} $	Differential output voltage magnitude, $ V_{OH}-V_{OL} $	2.5 V; 50 Ω from Y and Z to $V_{CC}-2$ V	0.6	0.8	1	
I_{OYZ} or I_{OZZ}	High-impedance output current	\overline{EN} at V_{CC} , $V_O = 0$ V or V_{CC}	-1		1	μ A
\overline{Q} OUTPUT CHARACTERISTICS (see Figure 1)						
V_{OH}	High-level output voltage	No load		$V_{CC}-0.94$		V
V_{OL}	Low-level output voltage	GC Tied to GND, No load		$V_{CC}-1.22$		V
		GC Open, No load		$V_{CC}-1.52$		
		GC Tied to V_{CC} , No load		$V_{CC}-1.82$		
$V_{O(pp)}$	Peak-to-peak output voltage	GC Tied to GND		300		mV
		GC Open		575		
		GC Tied to V_{CC}		860		

SWITCHING CHARACTERISTICS

over recommended operating conditions (unless otherwise noted)

PARAMETER		TEST CONDITIONS	MIN	TYP ⁽¹⁾	MAX	UNIT
t_{PD}	Propagation delay time, t_{PLH} or t_{PHL}	A to \overline{Q}		340	460	ps
		D to Y or Z	See Figure 4	460	630	
$t_{SK(P)}$	Pulse skew, $ t_{PLH}-t_{PHL} $			20		
$t_{SK(PP)}$	Part-to-part skew ⁽²⁾	$V_{CC} = 3.3$ V			80	ps
		$V_{CC} = 2.5$ V			130	
t_r	20%-to-80% differential signal rise time	See Figure 4		85	140	ps
t_f	20%-to-80% differential signal fall time	See Figure 4		85	140	ps
$t_{jit(per)}$	RMS period jitter ⁽³⁾	2-GHz 50%-duty-cycle square-wave input, See Figure 5		2	3	ps
$t_{jit(cc)}$	Peak cycle-to-cycle jitter ⁽⁴⁾			15	23	
$t_{jit(ph)}$	Intrinsic phase jitter	2 GHz		0.11		ps
t_{PHZ}	Propagation delay time, high-level-to-high-impedance output	See Figure 6			30	ns
t_{PLZ}	Propagation delay time, low-level-to-high-impedance output				30	
t_{PZH}	Propagation delay time, high-impedance-to-high-level output				30	
t_{PZL}	Propagation delay time, high-impedance-to-low-level output				30	

(1) Typical values are at room temperature and with a V_{CC} of 3.3 V.

(2) Part-to-part skew is the magnitude of the difference in propagation delay times between any specified terminals of two devices when both devices operate with the same supply voltages, at the same temperature, and have identical packages and test circuits.

(3) Period jitter is the deviation in cycle time of a signal with respect to the ideal period over a random sample of 100,000 cycles.

(4) Cycle-to-cycle jitter is the variation in cycle time of a signal between adjacent cycles, over a random sample of 1,000 adjacent cycle pairs.

PARAMETER MEASUREMENT INFORMATION

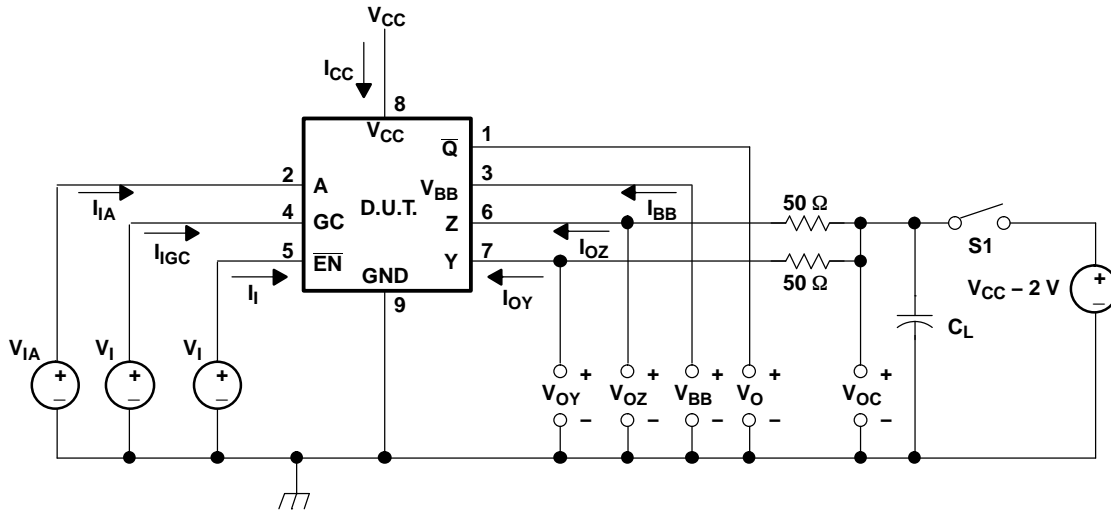

- (1) C_L is the instrumentation and test fixture capacitance.
- (2) S1 is open for the SN65LVDS16 and closed for the SN65LVP16.

Figure 1. Output Voltage Test Circuit and Voltage and Current Definitions for LVDS/LVP16

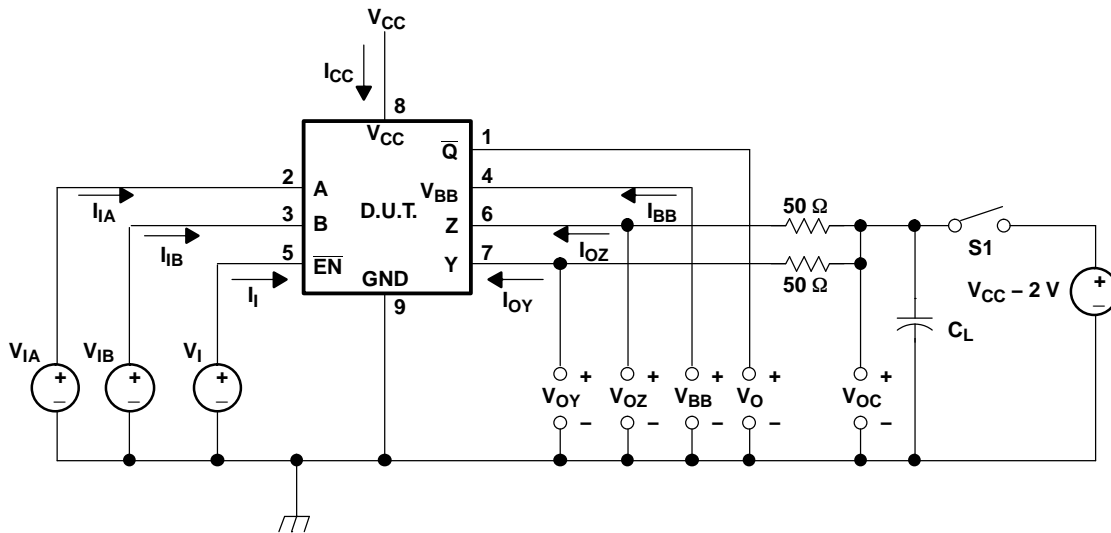

- (1) C_L is the instrumentation and test fixture capacitance.
- (2) S1 is open for the SN65LVDS17 and closed for the SN65LVP17.

Figure 2. Output Voltage Test Circuit and Voltage and Current Definitions for LVDS/LVP17

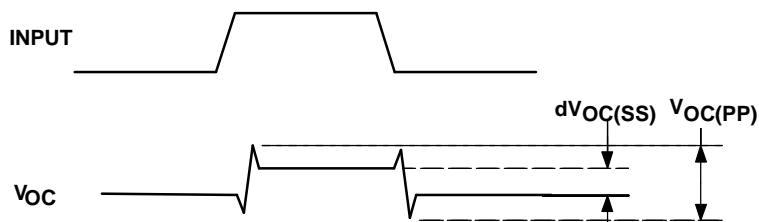

Figure 3. V_{OC} Definitions

PARAMETER MEASUREMENT INFORMATION (continued)

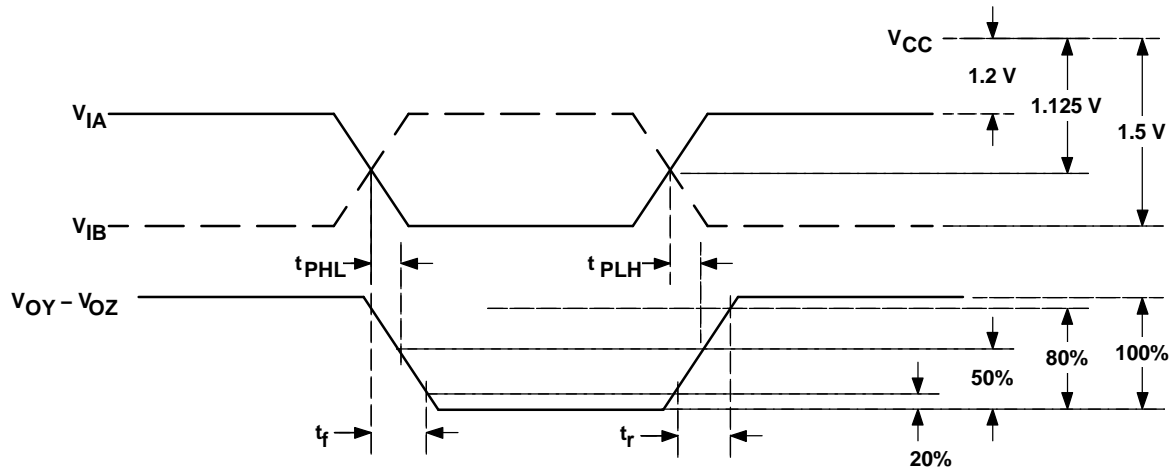

Figure 4. Propagation Delay and Transition Time Test Waveforms

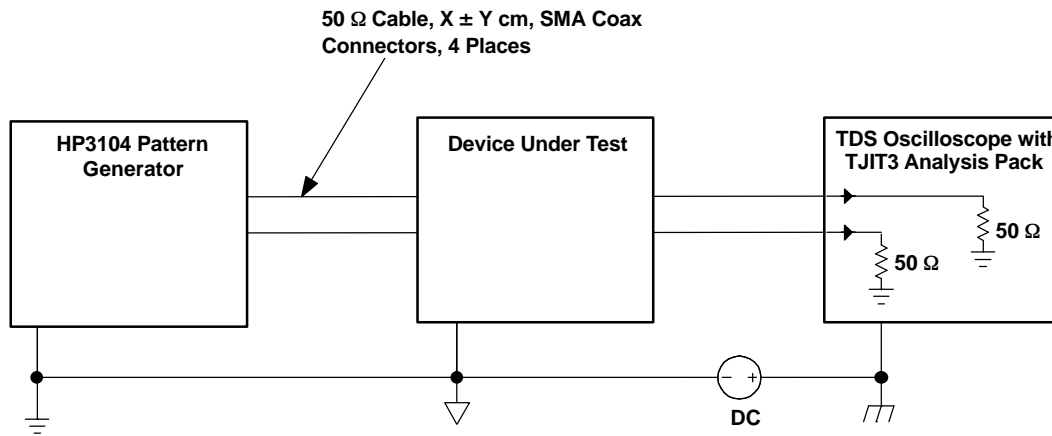

Figure 5. Jitter Measurement Setup

PARAMETER MEASUREMENT INFORMATION (continued)

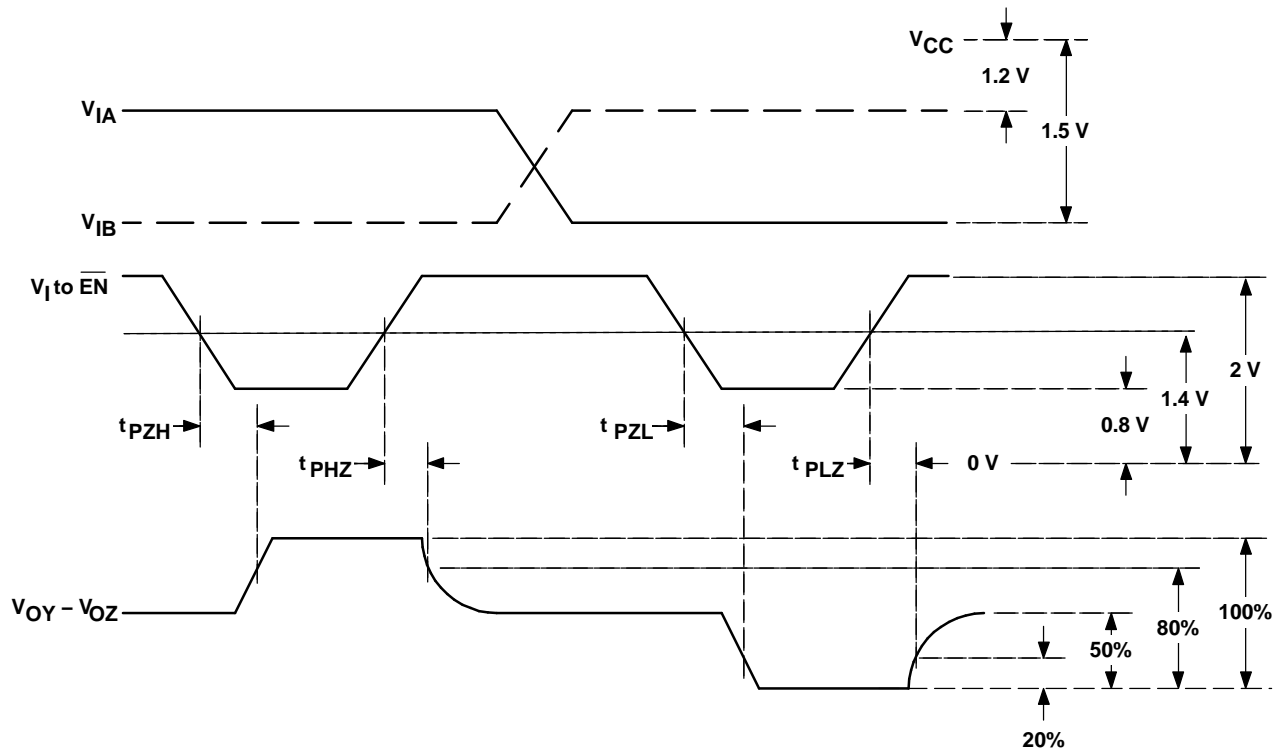

Figure 6. Enable and Disable Time Test Waveforms

DEVICE INFORMATION

FUNCTION TABLE

SN65LVDS16, SN65LVP16 ⁽¹⁾					SN65LVDS17, SN65LVP17 ⁽¹⁾					
A	\overline{EN}	\overline{Q}	Y	Z	A	B	\overline{EN}	\overline{Q}	Y	Z
H	L	L	H	L	H	H	L	?	?	?
L	L	H	L	H	L	H	L	H	L	H
X	H	?	Z	Z	H	L	L	L	H	L
Open	L	?	?	?	L	L	L	?	?	?
X	Open	?	?	?	X	X	H	?	Z	Z
					Open	Open	L	?	?	?
					X	X	Open	?	?	?

(1) H = high, L = low, Z = high impedance, ? = indeterminate

**DRF PACKAGE
TOP VIEW**

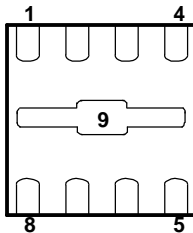
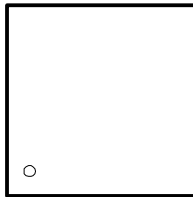

BOTTOM VIEW

Package Pin Assignments - Numerical Listing

SN65LVDS16, SN65LVP16		SN65LVDS17, SN65LVP17	
PIN	SIGNAL	PIN	SIGNAL
1	\overline{Q}	1	\overline{Q}
2	A	2	A
3	V_{BB}	3	B
4	GC	4	V_{BB}
5	\overline{EN}	5	\overline{EN}
6	Z	6	Z
7	Y	7	Y
8	V_{CC}	8	V_{CC}
9	GND	9	GND

TYPICAL CHARACTERISTICS

**SUPPLY CURRENT
VS
FREQUENCY**

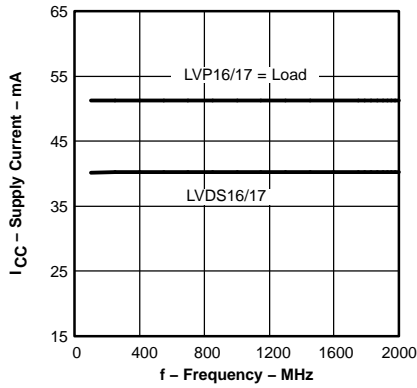

Figure 7.

**SUPPLY CURRENT
VS
FREE-AIR TEMPERATURE**

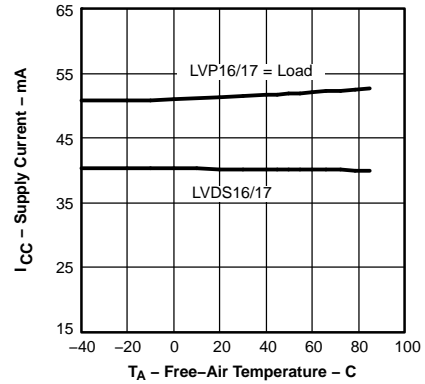

Figure 8.

**LVDS16/17 RISE/FALL TIME
VS
FREE-AIR TEMPERATURE**

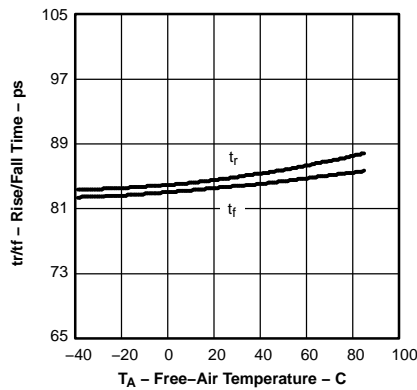

Figure 9.

**LVP16/17 RISE/FALL TIME
VS
FREE-AIR TEMPERATURE**

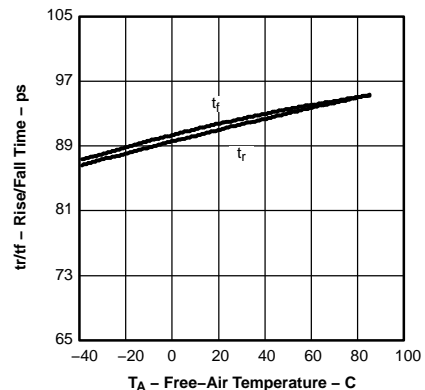

Figure 10.

**LVDS16/17
PROPAGATION DELAY TIME
VS
FREE-AIR TEMPERATURE**

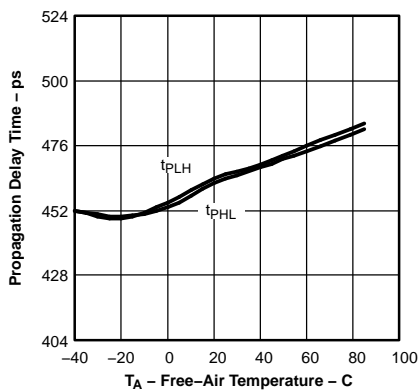

Figure 11.

**PERIOD JITTER
VS
FREQUENCY**

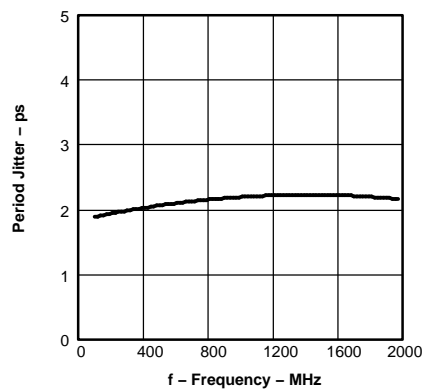

Figure 12.

**CYCLE-TO-CYCLE JITTER
VS
FREQUENCY**

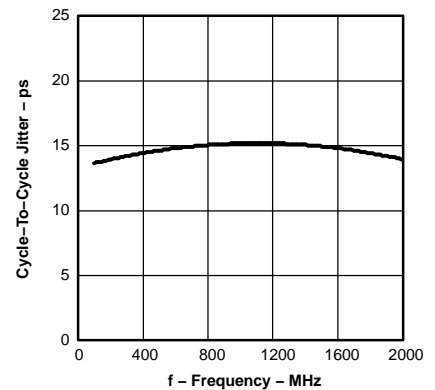
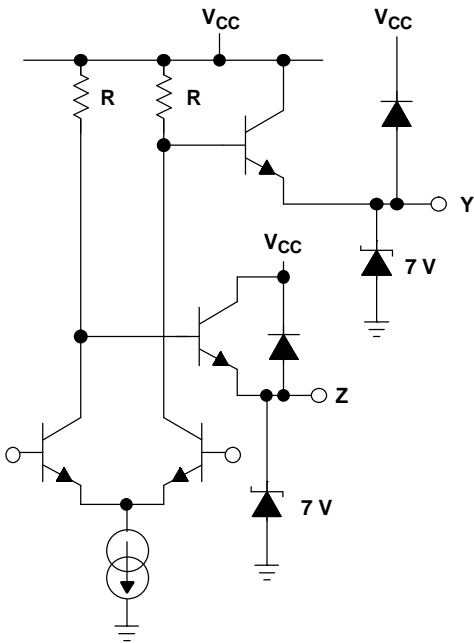

Figure 13.

EQUIVALENT INPUT AND OUTPUT SCHEMATIC DIAGRAMS

OUTPUT LVP16/17



OUTPUT LVDS16/17

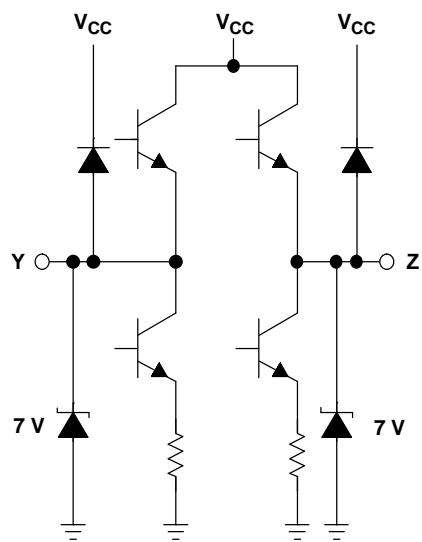

ENABLE

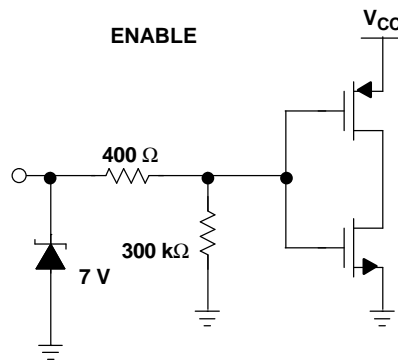

INPUT

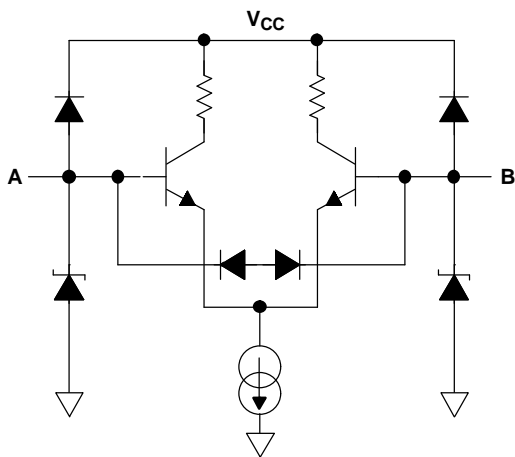

OUTPUT

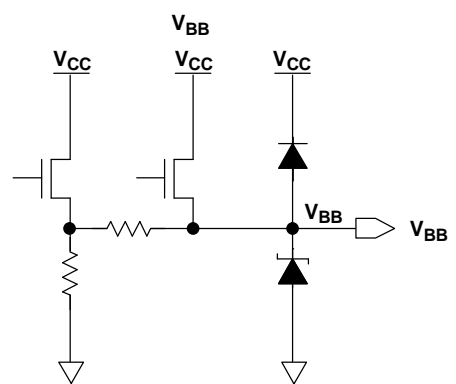

THERMAL INFORMATION

This package incorporates an exposed thermal pad that is designed to be attached directly to an external heatsink. The thermal pad must be soldered directly to the printed circuit board (PCB), the PCB can be used as a heatsink. In addition, through the use of thermal vias, the thermal pad can be attached directly to a ground plane or special heatsink structure designed into the PCB. This design optimizes the heat transfer from the integrated circuit (IC).

For information on the Quad Flatpack No-Lead (QFN) package and its advantages, refer to Application Report, Quad Flatpack No-Lead Logic Packages, Texas Instruments Literature No. SCBA017. This document is available at www.ti.com.

The exposed thermal pad dimensions for this package are shown in the following illustration.

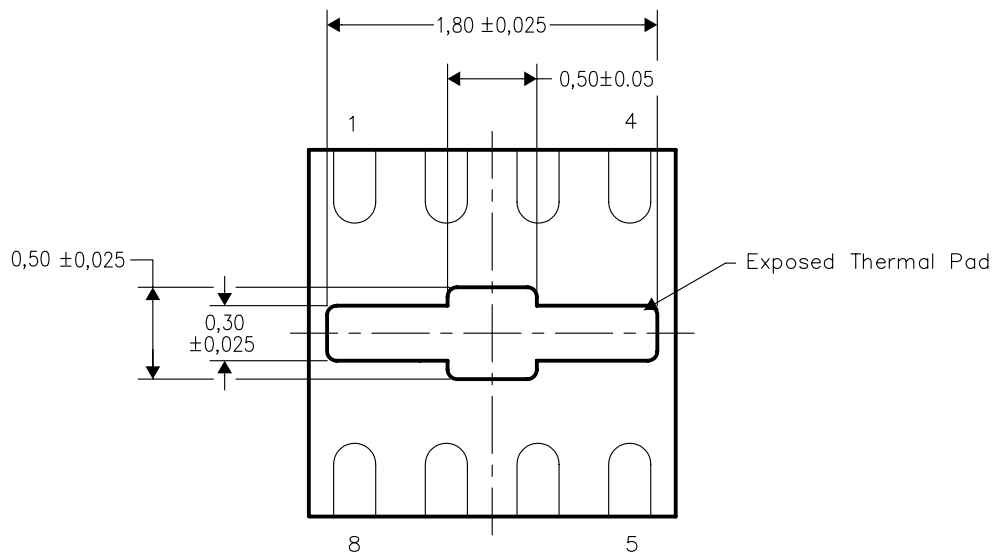

Bottom View

NOTE: All linear dimensions are in millimeters

Exposed Thermal Pad Dimensions

PACKAGING INFORMATION

Orderable Device	Status ⁽¹⁾	Package Type	Package Drawing	Pins	Package Qty	Eco Plan ⁽²⁾	Lead/Ball Finish	MSL Peak Temp ⁽³⁾
SN65LVDS16DRFR	ACTIVE	SON	DRF	8	3000	Green (RoHS & no Sb/Br)	CU NIPDAU	Level-1-260C-UNLIM
SN65LVDS16DRFRG4	ACTIVE	SON	DRF	8	3000	Green (RoHS & no Sb/Br)	CU NIPDAU	Level-1-260C-UNLIM
SN65LVDS16DRFT	ACTIVE	SON	DRF	8	250	Green (RoHS & no Sb/Br)	CU NIPDAU	Level-1-260C-UNLIM
SN65LVDS16DRFTG4	ACTIVE	SON	DRF	8	250	Green (RoHS & no Sb/Br)	CU NIPDAU	Level-1-260C-UNLIM
SN65LVDS17DRFR	ACTIVE	SON	DRF	8	3000	Green (RoHS & no Sb/Br)	CU NIPDAU	Level-1-260C-UNLIM
SN65LVDS17DRFRG4	ACTIVE	SON	DRF	8	3000	Green (RoHS & no Sb/Br)	CU NIPDAU	Level-1-260C-UNLIM
SN65LVDS17DRFT	ACTIVE	SON	DRF	8	250	Green (RoHS & no Sb/Br)	CU NIPDAU	Level-1-260C-UNLIM
SN65LVDS17DRFTG4	ACTIVE	SON	DRF	8	250	Green (RoHS & no Sb/Br)	CU NIPDAU	Level-1-260C-UNLIM
SN65LVP16DRFR	ACTIVE	SON	DRF	8	3000	Green (RoHS & no Sb/Br)	CU NIPDAU	Level-1-260C-UNLIM
SN65LVP16DRFRG4	ACTIVE	SON	DRF	8	3000	Green (RoHS & no Sb/Br)	CU NIPDAU	Level-1-260C-UNLIM
SN65LVP16DRFT	ACTIVE	SON	DRF	8	250	Green (RoHS & no Sb/Br)	CU NIPDAU	Level-1-260C-UNLIM
SN65LVP16DRFTG4	ACTIVE	SON	DRF	8	250	Green (RoHS & no Sb/Br)	CU NIPDAU	Level-1-260C-UNLIM
SN65LVP17DRFR	ACTIVE	SON	DRF	8	3000	Green (RoHS & no Sb/Br)	CU NIPDAU	Level-1-260C-UNLIM
SN65LVP17DRFRG4	ACTIVE	SON	DRF	8	3000	Green (RoHS & no Sb/Br)	CU NIPDAU	Level-1-260C-UNLIM
SN65LVP17DRFT	ACTIVE	SON	DRF	8	250	Green (RoHS & no Sb/Br)	CU NIPDAU	Level-1-260C-UNLIM
SN65LVP17DRFTG4	ACTIVE	SON	DRF	8	250	Green (RoHS & no Sb/Br)	CU NIPDAU	Level-1-260C-UNLIM

⁽¹⁾ The marketing status values are defined as follows:

ACTIVE: Product device recommended for new designs.

LIFEBUY: TI has announced that the device will be discontinued, and a lifetime-buy period is in effect.

NRND: Not recommended for new designs. Device is in production to support existing customers, but TI does not recommend using this part in a new design.

PREVIEW: Device has been announced but is not in production. Samples may or may not be available.

OBSOLETE: TI has discontinued the production of the device.

⁽²⁾ Eco Plan - The planned eco-friendly classification: Pb-Free (RoHS), Pb-Free (RoHS Exempt), or Green (RoHS & no Sb/Br) - please check <http://www.ti.com/productcontent> for the latest availability information and additional product content details.

TBD: The Pb-Free/Green conversion plan has not been defined.

Pb-Free (RoHS): TI's terms "Lead-Free" or "Pb-Free" mean semiconductor products that are compatible with the current RoHS requirements for all 6 substances, including the requirement that lead not exceed 0.1% by weight in homogeneous materials. Where designed to be soldered at high temperatures, TI Pb-Free products are suitable for use in specified lead-free processes.

Pb-Free (RoHS Exempt): This component has a RoHS exemption for either 1) lead-based flip-chip solder bumps used between the die and package, or 2) lead-based die adhesive used between the die and leadframe. The component is otherwise considered Pb-Free (RoHS compatible) as defined above.

Green (RoHS & no Sb/Br): TI defines "Green" to mean Pb-Free (RoHS compatible), and free of Bromine (Br) and Antimony (Sb) based flame retardants (Br or Sb do not exceed 0.1% by weight in homogeneous material)

⁽³⁾ MSL, Peak Temp. -- The Moisture Sensitivity Level rating according to the JEDEC industry standard classifications, and peak solder temperature.

Important Information and Disclaimer:The information provided on this page represents TI's knowledge and belief as of the date that it is provided. TI bases its knowledge and belief on information provided by third parties, and makes no representation or warranty as to the accuracy of such information. Efforts are underway to better integrate information from third parties. TI has taken and continues to take reasonable steps to provide representative and accurate information but may not have conducted destructive testing or chemical analysis on incoming materials and chemicals. TI and TI suppliers consider certain information to be proprietary, and thus CAS numbers and other limited information may not be available for release.

In no event shall TI's liability arising out of such information exceed the total purchase price of the TI part(s) at issue in this document sold by TI to Customer on an annual basis.

TAPE AND REEL INFORMATION



QUADRANT ASSIGNMENTS FOR PIN 1 ORIENTATION IN TAPE



*All dimensions are nominal

Device	Package Type	Package Drawing	Pins	SPQ	Reel Diameter (mm)	Reel Width W1 (mm)	A0 (mm)	B0 (mm)	K0 (mm)	P1 (mm)	W (mm)	Pin1 Quadrant
SN65LVDS16DRFR	SON	DRF	8	3000	330.0	8.8	2.3	2.3	1.0	4.0	8.0	Q2
SN65LVDS16DRFT	SON	DRF	8	250	330.0	8.8	2.3	2.3	1.0	4.0	8.0	Q2
SN65LVDS17DRFR	SON	DRF	8	3000	330.0	8.8	2.3	2.3	1.0	4.0	8.0	Q2
SN65LVDS17DRFT	SON	DRF	8	250	330.0	8.8	2.3	2.3	1.0	4.0	8.0	Q2
SN65LVP16DRFR	SON	DRF	8	3000	330.0	8.8	2.3	2.3	1.0	4.0	8.0	Q2
SN65LVP16DRFT	SON	DRF	8	250	330.0	8.8	2.3	2.3	1.0	4.0	8.0	Q2
SN65LVP17DRFR	SON	DRF	8	3000	330.0	8.8	2.3	2.3	1.0	4.0	8.0	Q2
SN65LVP17DRFT	SON	DRF	8	250	330.0	8.8	2.3	2.3	1.0	4.0	8.0	Q2

TAPE AND REEL BOX DIMENSIONS



*All dimensions are nominal

Device	Package Type	Package Drawing	Pins	SPQ	Length (mm)	Width (mm)	Height (mm)
SN65LVDS16DRFR	SON	DRF	8	3000	337.0	343.0	29.0
SN65LVDS16DRFT	SON	DRF	8	250	337.0	343.0	29.0
SN65LVDS17DRFR	SON	DRF	8	3000	337.0	343.0	29.0
SN65LVDS17DRFT	SON	DRF	8	250	337.0	343.0	29.0
SN65LVP16DRFR	SON	DRF	8	3000	337.0	343.0	29.0
SN65LVP16DRFT	SON	DRF	8	250	337.0	343.0	29.0
SN65LVP17DRFR	SON	DRF	8	3000	337.0	343.0	29.0
SN65LVP17DRFT	SON	DRF	8	250	337.0	343.0	29.0

DRF (S-PDSO-N8)

PLASTIC SMALL OUTLINE

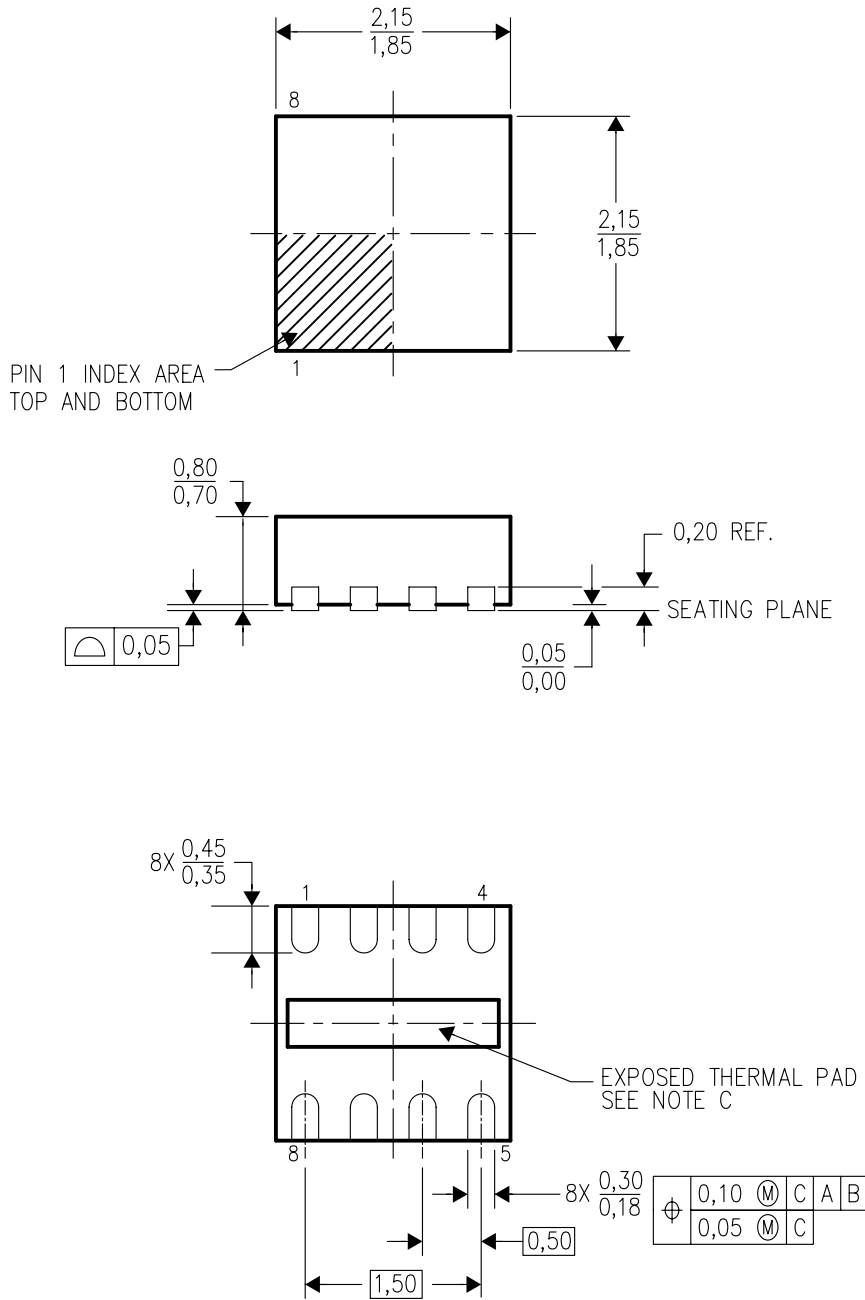

4205287/D 07/05

- NOTES:
- A. All linear dimensions are in millimeters.
 - B. This drawing is subject to change without notice.
 - C. The Package thermal pad must be soldered to the board for thermal and mechanical performance. See product data sheet for details regarding the exposed thermal pad dimensions.
 - D. Falls within JEDEC MO-229.

THERMAL INFORMATION

This package incorporates an exposed thermal pad that is designed to be attached directly to an external heatsink. The thermal pad must be soldered directly to the printed circuit board (PCB). After soldering, the PCB can be used as a heatsink. In addition, through the use of thermal vias, the thermal pad can be attached directly to the appropriate copper plane shown in the electrical schematic for the device, or alternatively, can be attached to a special heatsink structure designed into the PCB. This design optimizes the heat transfer from the integrated circuit (IC).

For information on the Quad Flatpack No-Lead (QFN) package and its advantages, refer to Application Report, Quad Flatpack No-Lead Logic Packages, Texas Instruments Literature No. SCBA017. This document is available at www.ti.com.

The exposed thermal pad dimensions for this package are shown in the following illustration.

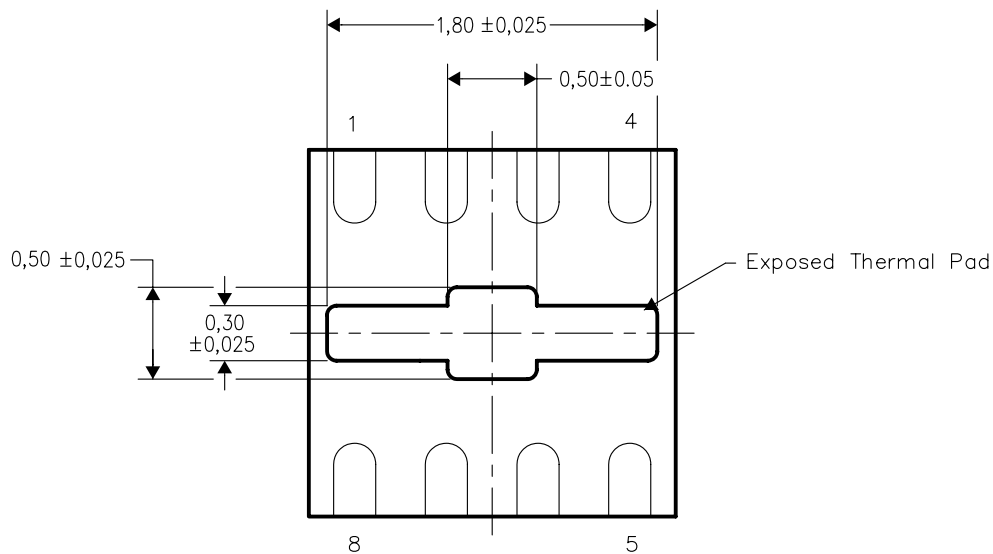

Bottom View

NOTE: All linear dimensions are in millimeters

Exposed Thermal Pad Dimensions

IMPORTANT NOTICE

Texas Instruments Incorporated and its subsidiaries (TI) reserve the right to make corrections, modifications, enhancements, improvements, and other changes to its products and services at any time and to discontinue any product or service without notice. Customers should obtain the latest relevant information before placing orders and should verify that such information is current and complete. All products are sold subject to TI's terms and conditions of sale supplied at the time of order acknowledgment.

TI warrants performance of its hardware products to the specifications applicable at the time of sale in accordance with TI's standard warranty. Testing and other quality control techniques are used to the extent TI deems necessary to support this warranty. Except where mandated by government requirements, testing of all parameters of each product is not necessarily performed.

TI assumes no liability for applications assistance or customer product design. Customers are responsible for their products and applications using TI components. To minimize the risks associated with customer products and applications, customers should provide adequate design and operating safeguards.

TI does not warrant or represent that any license, either express or implied, is granted under any TI patent right, copyright, mask work right, or other TI intellectual property right relating to any combination, machine, or process in which TI products or services are used. Information published by TI regarding third-party products or services does not constitute a license from TI to use such products or services or a warranty or endorsement thereof. Use of such information may require a license from a third party under the patents or other intellectual property of the third party, or a license from TI under the patents or other intellectual property of TI.

Reproduction of TI information in TI data books or data sheets is permissible only if reproduction is without alteration and is accompanied by all associated warranties, conditions, limitations, and notices. Reproduction of this information with alteration is an unfair and deceptive business practice. TI is not responsible or liable for such altered documentation. Information of third parties may be subject to additional restrictions.

Resale of TI products or services with statements different from or beyond the parameters stated by TI for that product or service voids all express and any implied warranties for the associated TI product or service and is an unfair and deceptive business practice. TI is not responsible or liable for any such statements.

TI products are not authorized for use in safety-critical applications (such as life support) where a failure of the TI product would reasonably be expected to cause severe personal injury or death, unless officers of the parties have executed an agreement specifically governing such use. Buyers represent that they have all necessary expertise in the safety and regulatory ramifications of their applications, and acknowledge and agree that they are solely responsible for all legal, regulatory and safety-related requirements concerning their products and any use of TI products in such safety-critical applications, notwithstanding any applications-related information or support that may be provided by TI. Further, Buyers must fully indemnify TI and its representatives against any damages arising out of the use of TI products in such safety-critical applications.

TI products are neither designed nor intended for use in military/aerospace applications or environments unless the TI products are specifically designated by TI as military-grade or "enhanced plastic." Only products designated by TI as military-grade meet military specifications. Buyers acknowledge and agree that any such use of TI products which TI has not designated as military-grade is solely at the Buyer's risk, and that they are solely responsible for compliance with all legal and regulatory requirements in connection with such use.

TI products are neither designed nor intended for use in automotive applications or environments unless the specific TI products are designated by TI as compliant with ISO/TS 16949 requirements. Buyers acknowledge and agree that, if they use any non-designated products in automotive applications, TI will not be responsible for any failure to meet such requirements.

Following are URLs where you can obtain information on other Texas Instruments products and application solutions:

Products

Amplifiers	amplifier.ti.com
Data Converters	dataconverter.ti.com
DSP	dsp.ti.com
Clocks and Timers	www.ti.com/clocks
Interface	interface.ti.com
Logic	logic.ti.com
Power Mgmt	power.ti.com
Microcontrollers	microcontroller.ti.com
RFID	www.ti-rfid.com
RF/IF and ZigBee® Solutions	www.ti.com/lprf

Applications

Audio	www.ti.com/audio
Automotive	www.ti.com/automotive
Broadband	www.ti.com/broadband
Digital Control	www.ti.com/digitalcontrol
Medical	www.ti.com/medical
Military	www.ti.com/military
Optical Networking	www.ti.com/opticalnetwork
Security	www.ti.com/security
Telephony	www.ti.com/telephony
Video & Imaging	www.ti.com/video
Wireless	www.ti.com/wireless

Mailing Address: Texas Instruments, Post Office Box 655303, Dallas, Texas 75265
Copyright © 2008, Texas Instruments Incorporated